

6

5

4

3

2

1

| REVISION RECORD |                               |            |
|-----------------|-------------------------------|------------|
| REV             | REVISIONS DONE OR ECO NUMBER: | DATE:      |
| A.01            | Changed 4 caps to C200-203    | RB 2/27/98 |
|                 |                               |            |
|                 |                               |            |
|                 |                               |            |

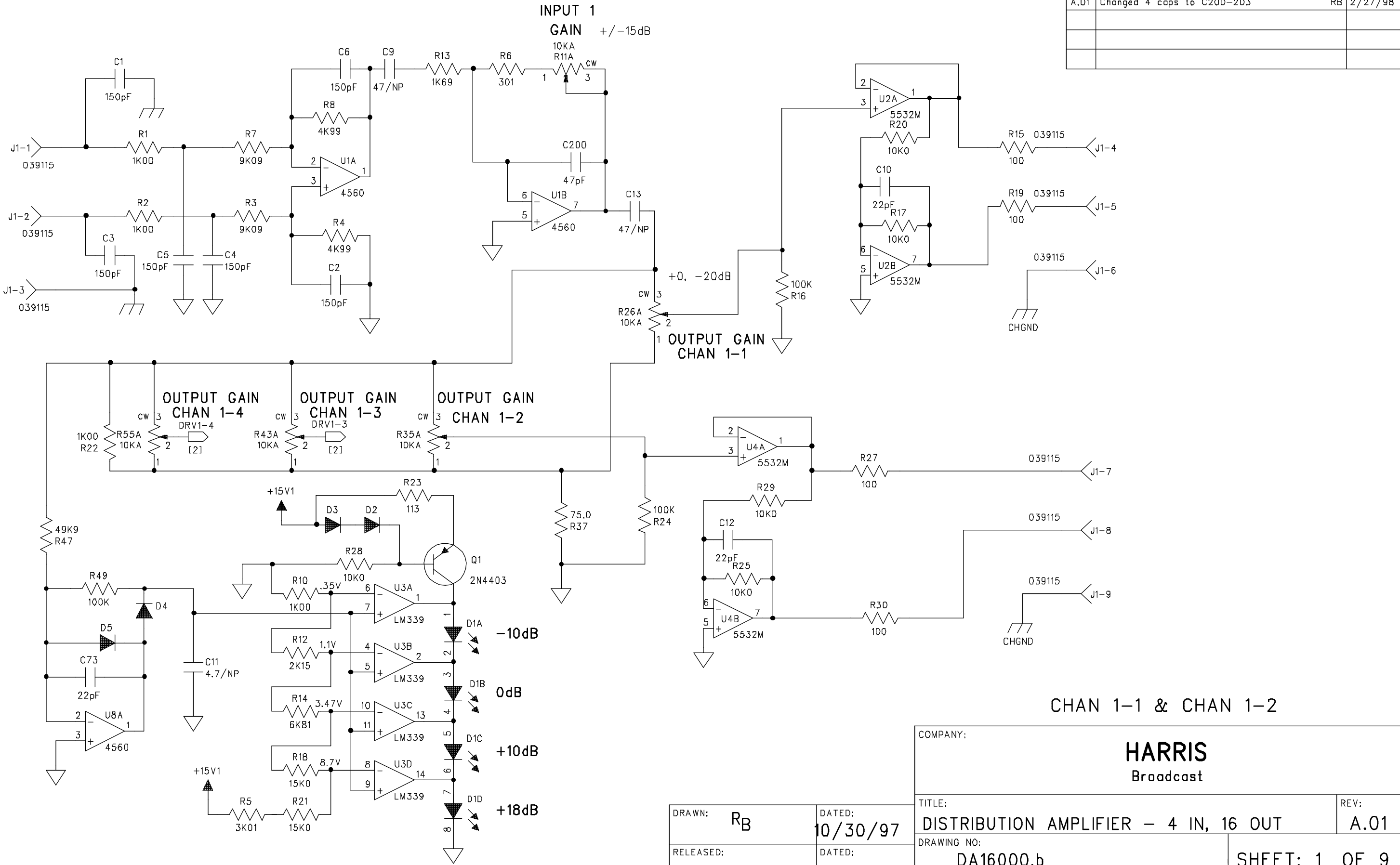

CHAN 1-1 & CHAN 1-2

|               |  |                                       |  |
|---------------|--|---------------------------------------|--|
| COMPANY:      |  | <b>HARRIS</b><br>Broadcast            |  |
| TITLE:        |  | DISTRIBUTION AMPLIFIER - 4 IN, 16 OUT |  |
| DRAWING NO:   |  | DA16000.b                             |  |
| SHEET: 1 OF 9 |  | REV: A.01                             |  |

|           |    |        |          |
|-----------|----|--------|----------|
| DRAWN:    | RB | DATED: | 10/30/97 |
| RELEASED: |    | DATED: |          |

6

5

4

3

2

1

REVISION RECORD

| REV | REVISIONS DONE OR ECO NUMBER: | DATE: |
|-----|-------------------------------|-------|
|     |                               |       |
|     |                               |       |
|     |                               |       |
|     |                               |       |

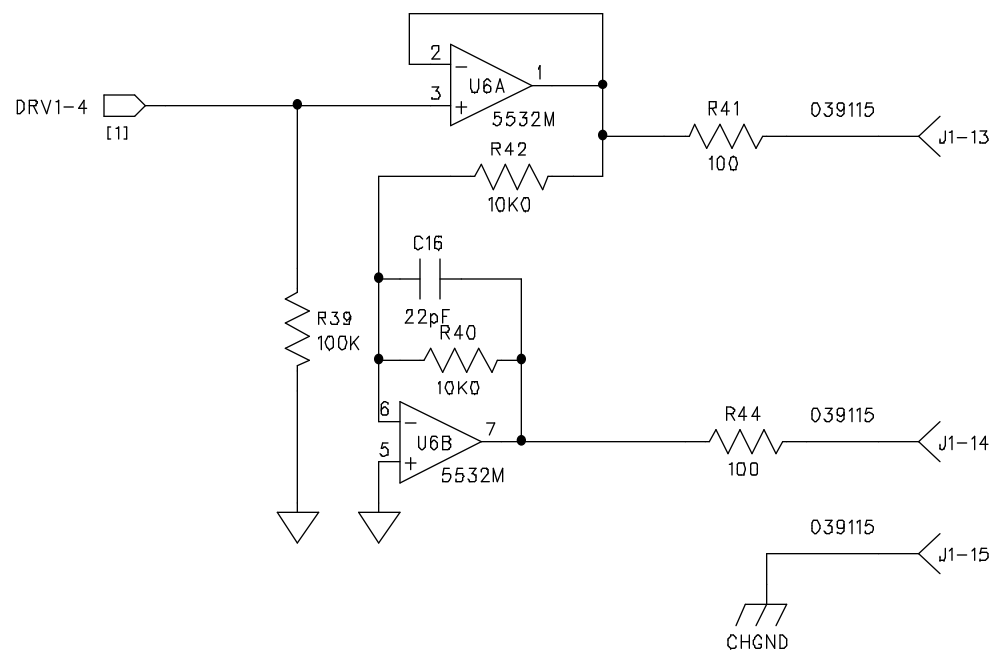
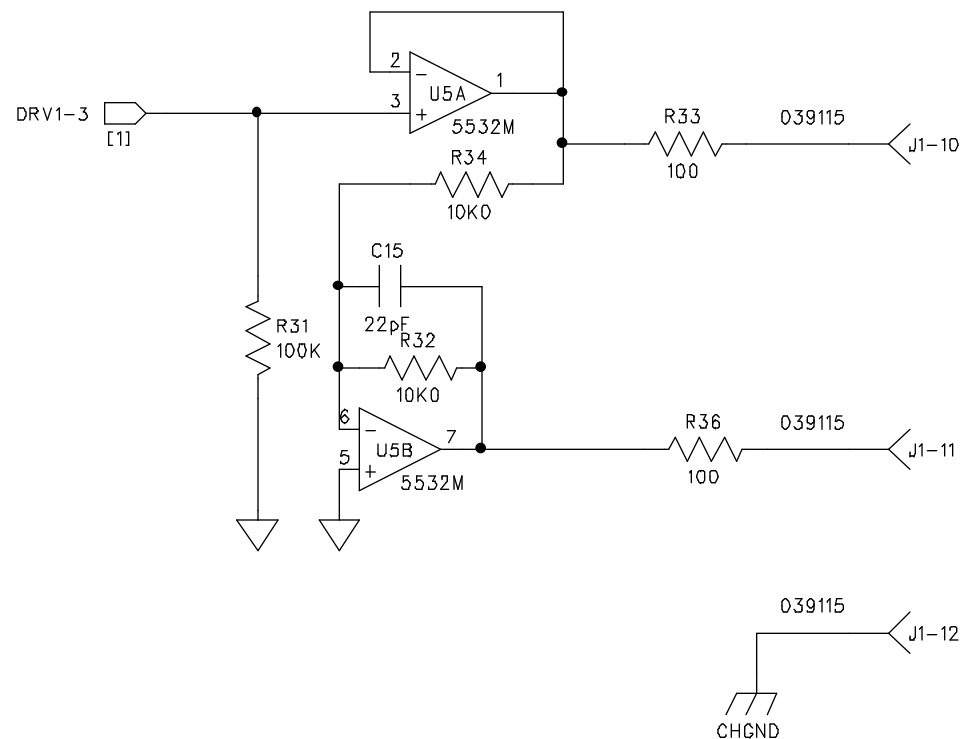

COMPANY: **HARRIS**  
Broadcast

TITLE: **DISTRIBUTION AMP - CHAN 1-3 & 1-4** REV: **A.01**

DRAWING NO: **DA16000.b** SHEET: **2 OF 9**

DRAWN: \_\_\_\_\_ DATED: \_\_\_\_\_  
RELEASED: \_\_\_\_\_ DATED: \_\_\_\_\_

D

C

B

A

6

5

4

3

2

1

REVISION RECORD

| REV | REVISIONS DONE OR ECO NUMBER: | DATE: |
|-----|-------------------------------|-------|
|     |                               |       |
|     |                               |       |
|     |                               |       |
|     |                               |       |

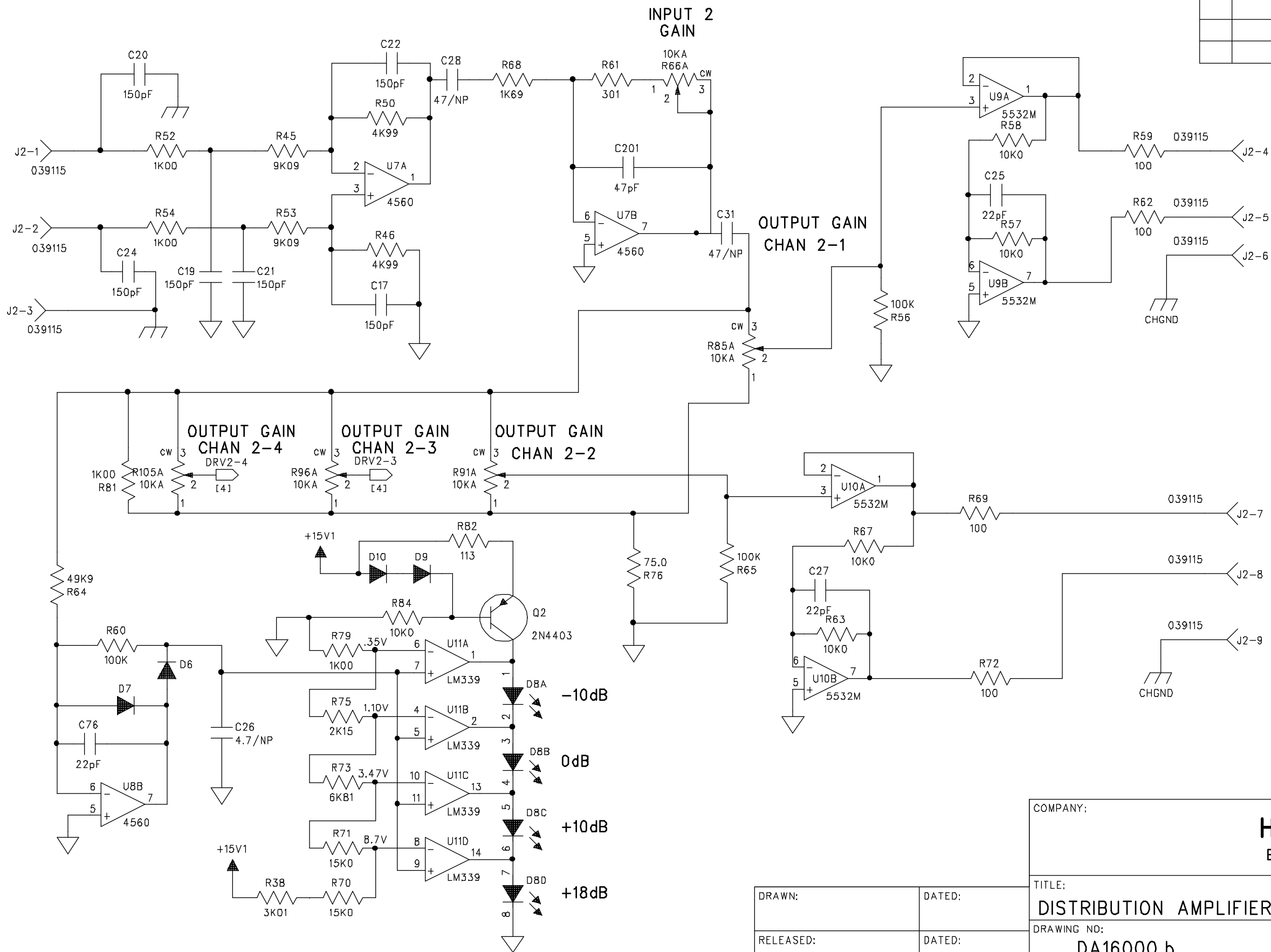

|               |  |   |  |
|---------------|--|---|--|
| COMPANY:      |  | <b>HARRIS</b><br>Broadcast              |  |
| TITLE:        |  | DISTRIBUTION AMPLIFIER - CHAN 2-1 & 2-2 |  |
| DRAWING NO:   |  | DA16000.b                               |  |
| REV:          |  | A.01                                    |  |
| SHEET: 3 OF 9 |  |   |  |

|           |        |
|-----------|--------|
| DRAWN:    | DATED: |
| RELEASED: | DATED: |

6

5

4

3

2

1

| REVISION RECORD |                               |       |
|-----------------|-------------------------------|-------|
| REV             | REVISIONS DONE OR ECO NUMBER: | DATE: |
|                 |                               |       |
|                 |                               |       |
|                 |                               |       |
|                 |                               |       |

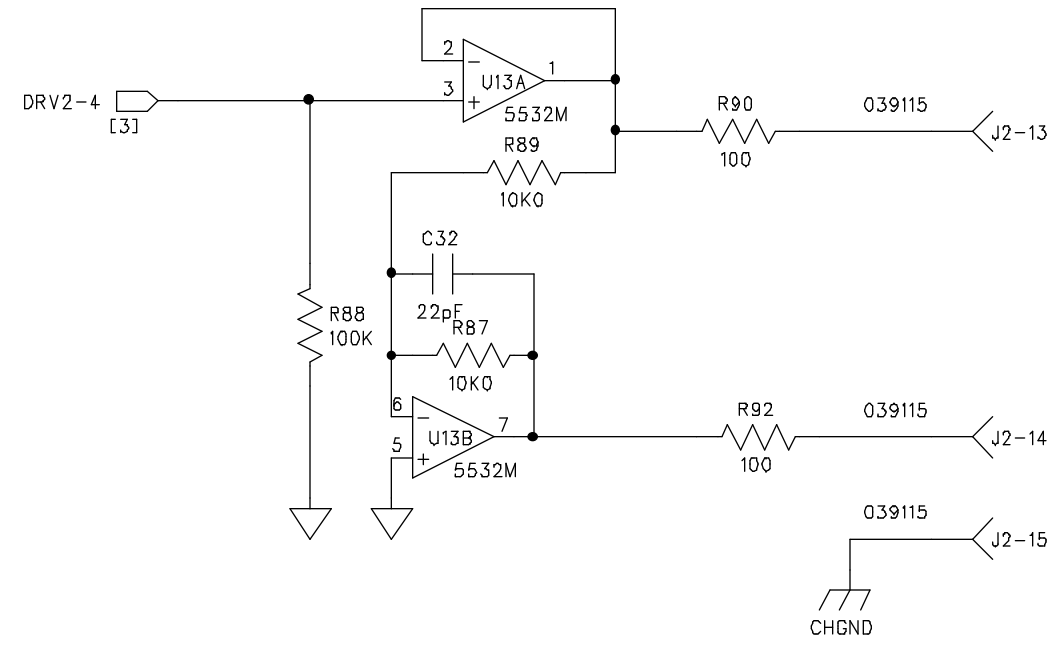
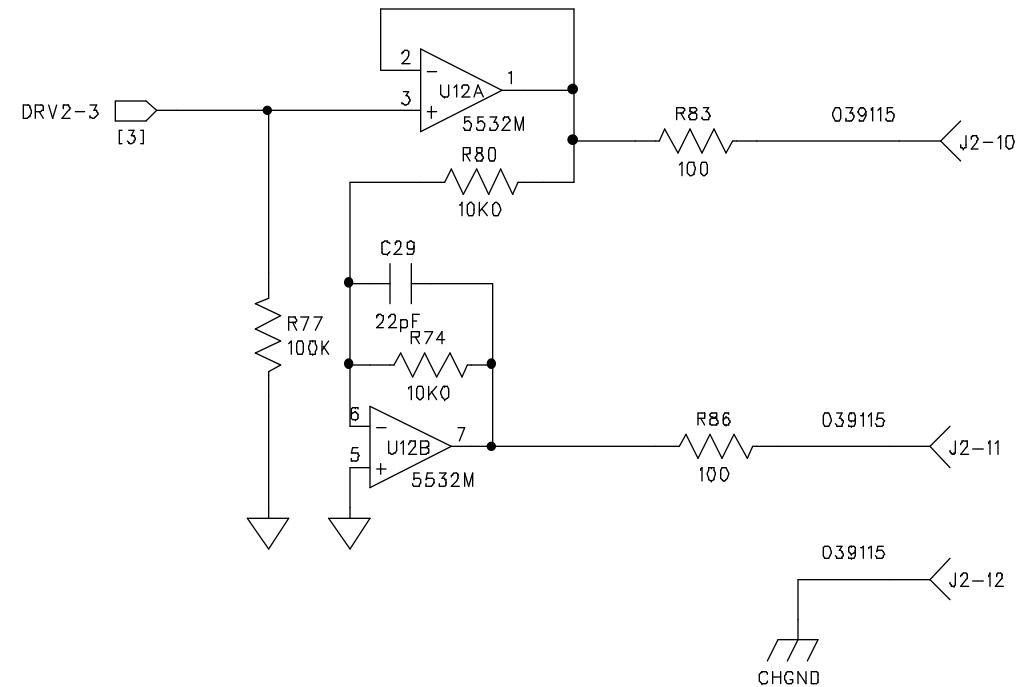

|               |  |                                   |  |
|---------------|--|-----------------------------------|--|
| COMPANY:      |  | <b>HARRIS</b><br>Broadcast        |  |
| TITLE:        |  | DISTRIBUTION AMP - CHAN 2-3 & 2-4 |  |
| DRAWING NO:   |  | DA16000.b                         |  |
| SHEET: 4 OF 9 |  | REV: A.01                         |  |

|           |        |
|-----------|--------|
| DRAWN:    | DATED: |
| RELEASED: | DATED: |

D

D

C

C

B

B

A

A

6

5

4

3

2

1

REVISION RECORD

| REV | REVISIONS DONE OR ECO NUMBER: | DATE: |
|-----|-------------------------------|-------|
|     |                               |       |
|     |                               |       |
|     |                               |       |
|     |                               |       |

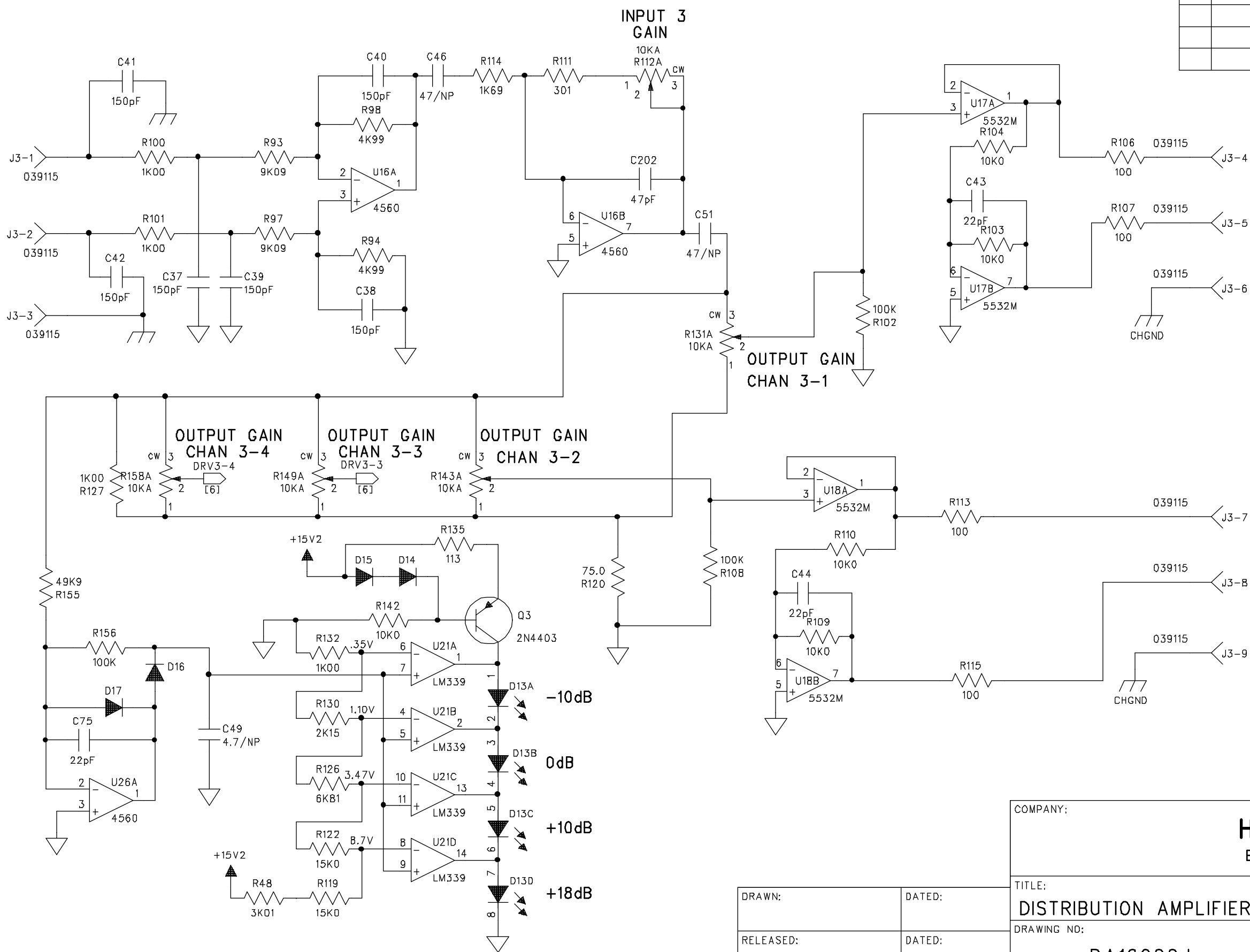

COMPANY: **HARRIS**  
Broadcast

TITLE: **DISTRIBUTION AMPLIFIER - CHAN 3-1 & 3-2**

REV: **A.01**

DRAWING NO: **DA16000.b**

SHEET: **5 OF 9**

|           |        |
|-----------|--------|
| DRAWN:    | DATED: |
| RELEASED: | DATED: |

6

5

4

3

2

1

REVISION RECORD

| REV | REVISIONS DONE OR ECO NUMBER: | DATE: |
|-----|-------------------------------|-------|
|     |                               |       |
|     |                               |       |
|     |                               |       |
|     |                               |       |

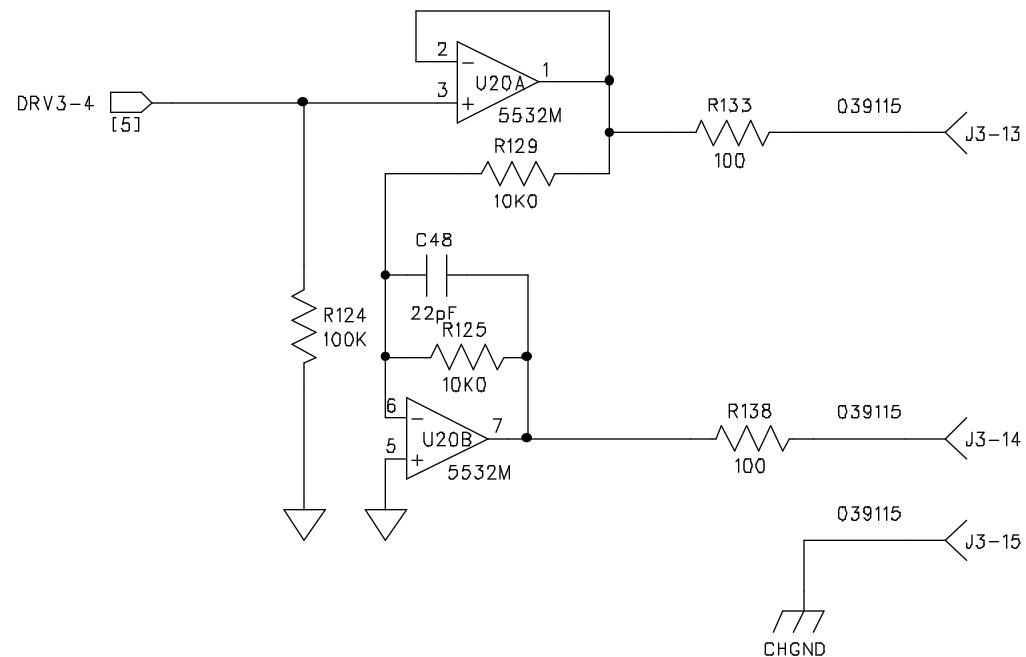
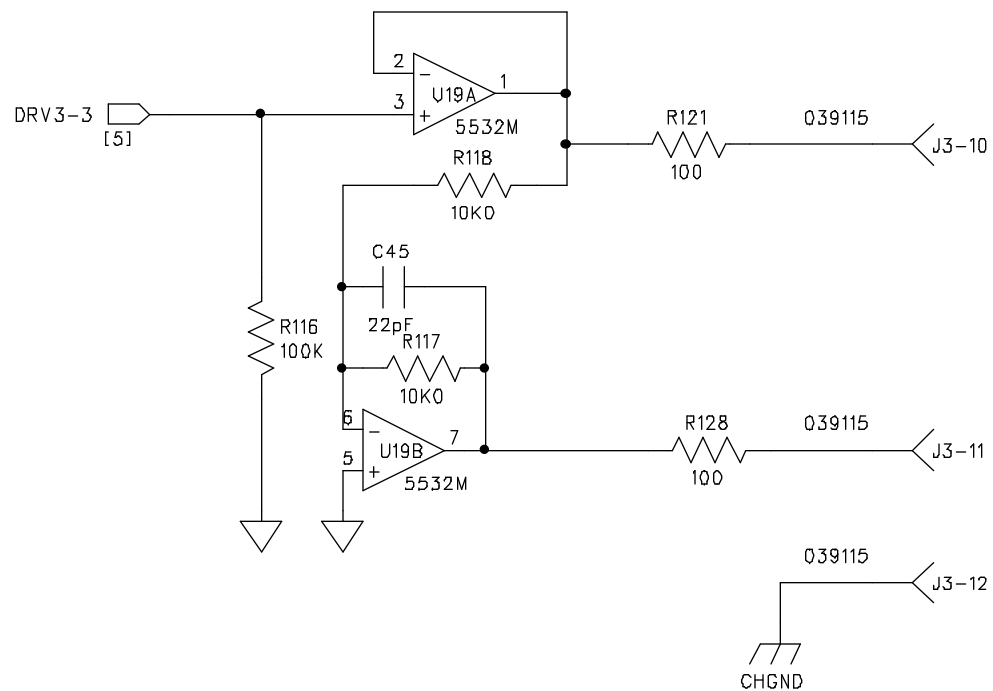

COMPANY: **HARRIS**  
Broadcast

TITLE: DISTRIBUTION AMP - CHAN 3-3 & 3-4 REV: A.01

DRAWING NO: DA16000.b SHEET: 6 OF 9

DRAWN: DATED: RELEASED: DATED:

6

5

4

3

2

1

REVISION RECORD

| REV | REVISIONS DONE OR ECO NUMBER: | DATE: |
|-----|-------------------------------|-------|
|     |                               |       |
|     |                               |       |
|     |                               |       |
|     |                               |       |

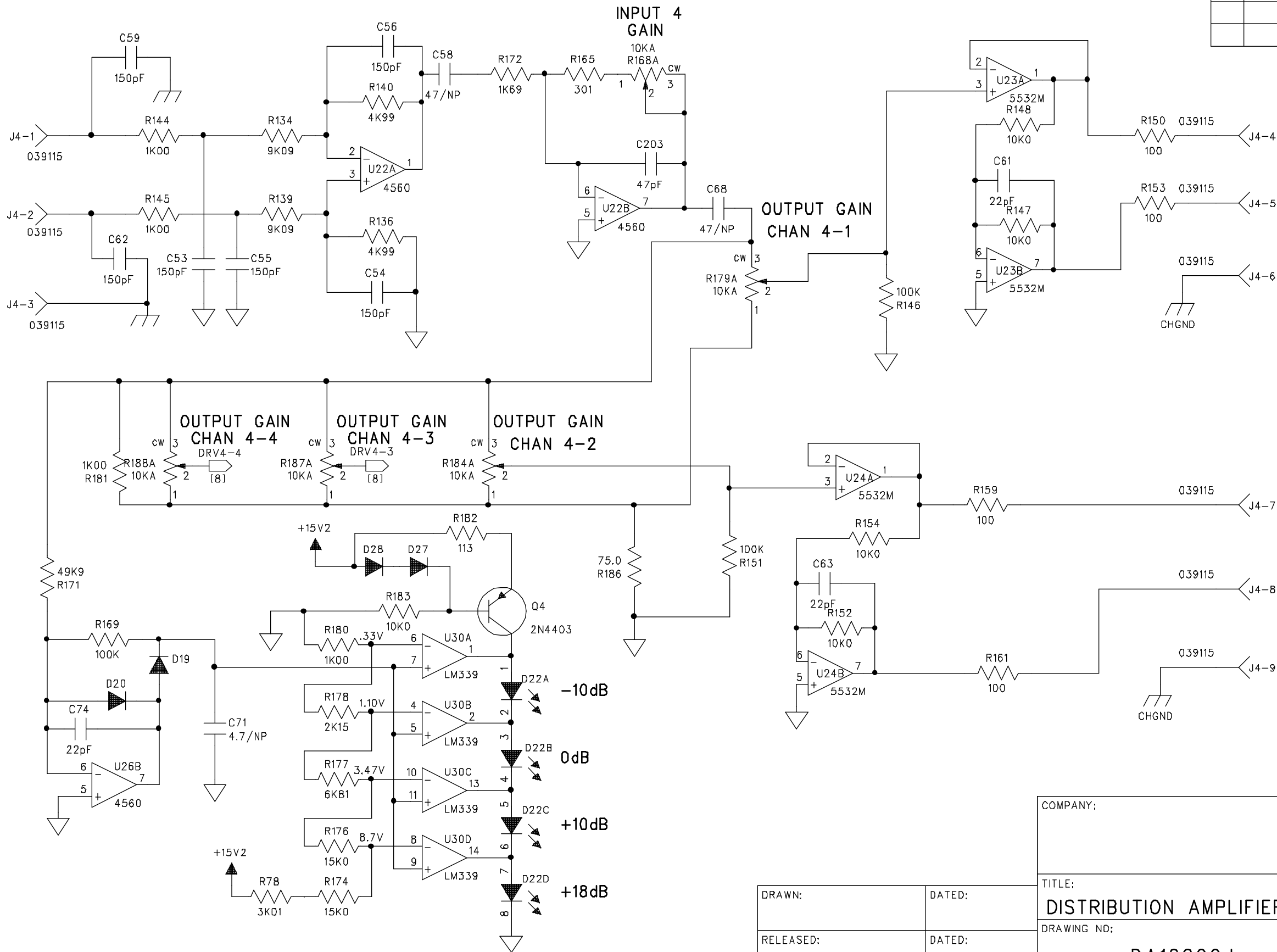

COMPANY: **HARRIS Broadcast**

TITLE: **DISTRIBUTION AMPLIFIER - 4-1 & 4-2**

DRAWING NO: **DA16000.b**

SHEET: **7 OF 9**

REV: **A.01**

|           |        |
|-----------|--------|
| DRAWN:    | DATED: |
| RELEASED: | DATED: |

6

5

4

3

2

1

| REVISION RECORD |                               |       |
|-----------------|-------------------------------|-------|
| REV             | REVISIONS DONE OR ECO NUMBER: | DATE: |
|                 |                               |       |
|                 |                               |       |
|                 |                               |       |
|                 |                               |       |

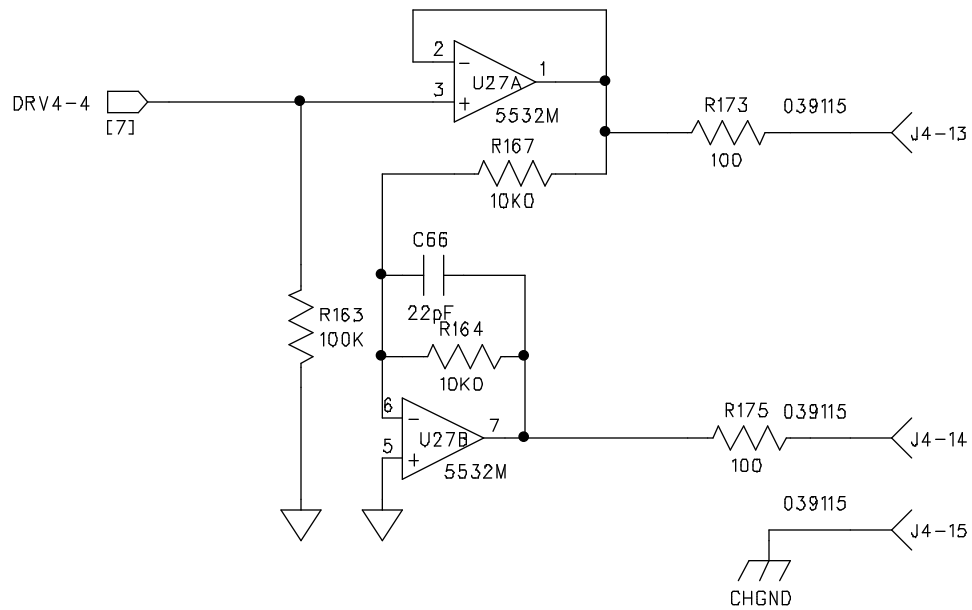
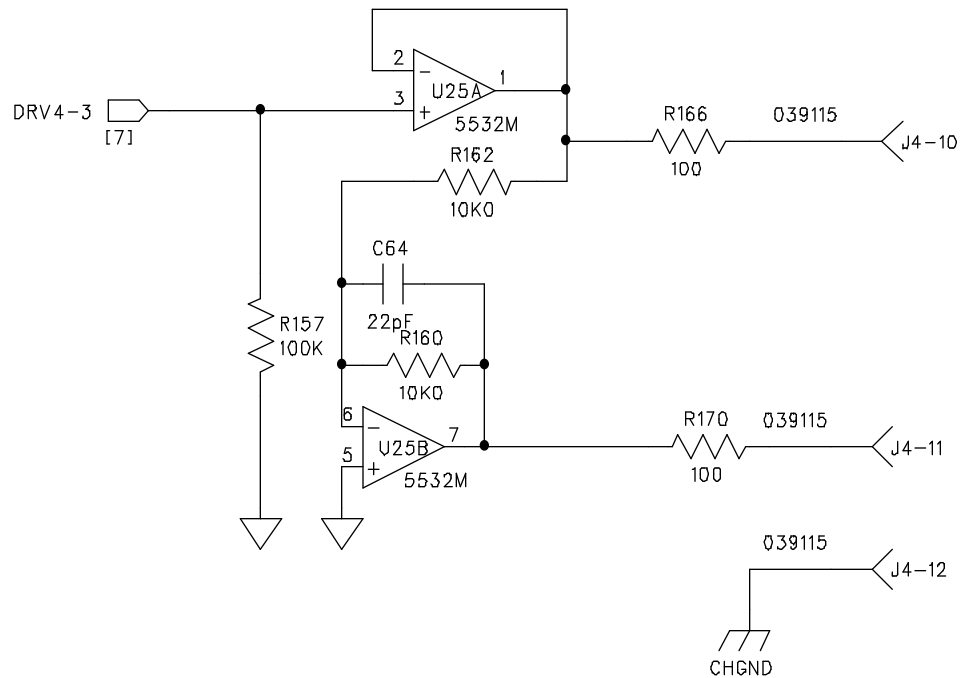

|               |  |                              |  |
|---------------|--|------------------------------|--|
| COMPANY:      |  | <b>HARRIS</b><br>Broadcast   |  |
| TITLE:        |  | DISTRIBUTION AMP - 4-3 & 4-4 |  |
| DRAWING NO:   |  | DA16000.b                    |  |
| SHEET: 8 OF 9 |  | REV: A.01                    |  |

|           |        |
|-----------|--------|
| DRAWN:    | DATED: |
| RELEASED: | DATED: |

D

C

B

A

D

C

B

A



6

5

4

3

2

1

REVISION RECORD

| REV | REVISIONS DONE OR ECO NUMBER: | DATE: |
|-----|-------------------------------|-------|
|     |                               |       |
|     |                               |       |
|     |                               |       |
|     |                               |       |

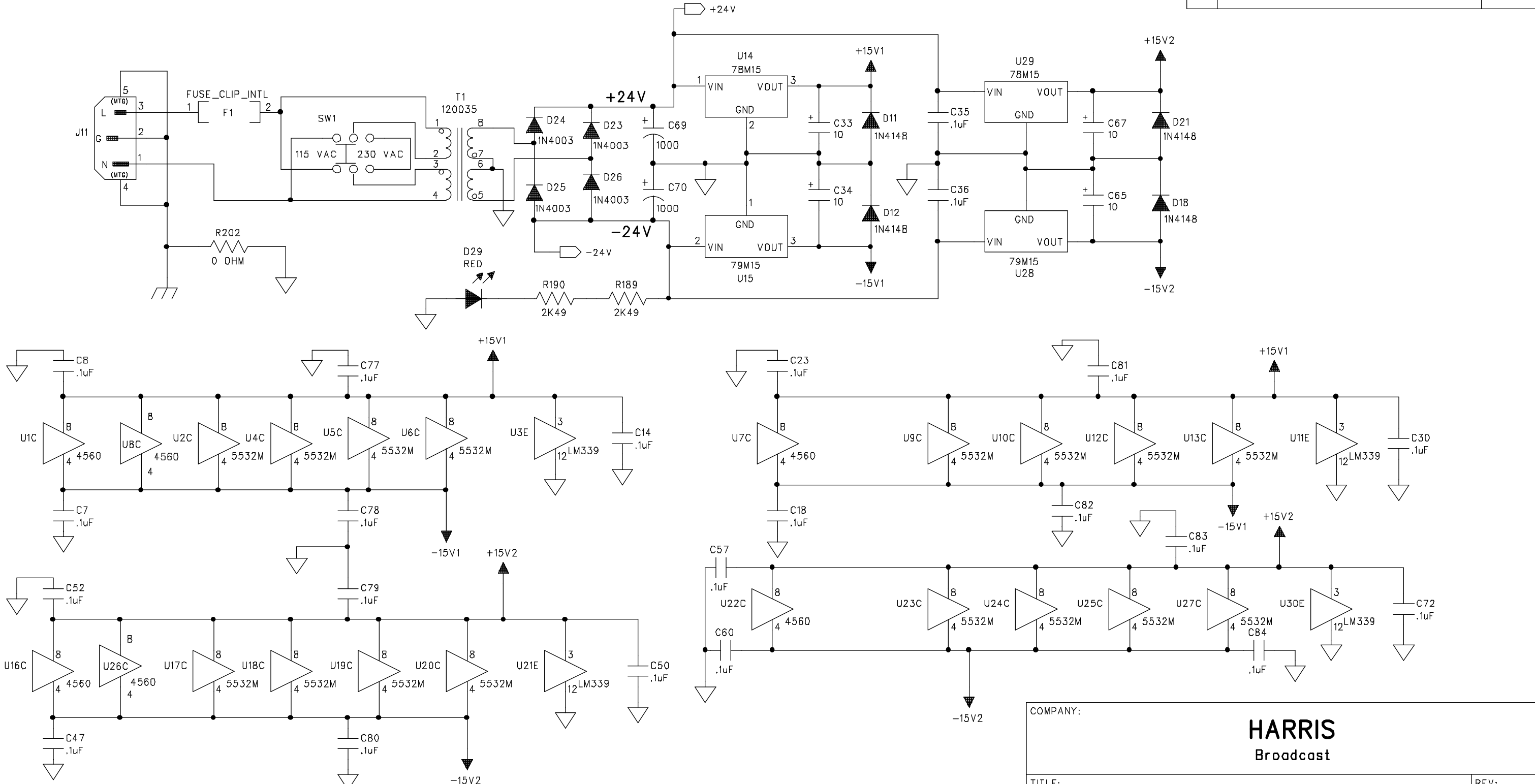

COMPANY:  
**HARRIS**  
Broadcast

TITLE: **POWER SUPPLY & DISTRIBUTION** REV: **A.01**

DRAWING NO: **DA16000.b** SHEET: **9 OF 9**

DRAWN: \_\_\_\_\_ DATED: \_\_\_\_\_

RELEASED: \_\_\_\_\_ DATED: \_\_\_\_\_